

Partner: WallWizard
Model: SA52/TA55
Device Type: Motorized Mount

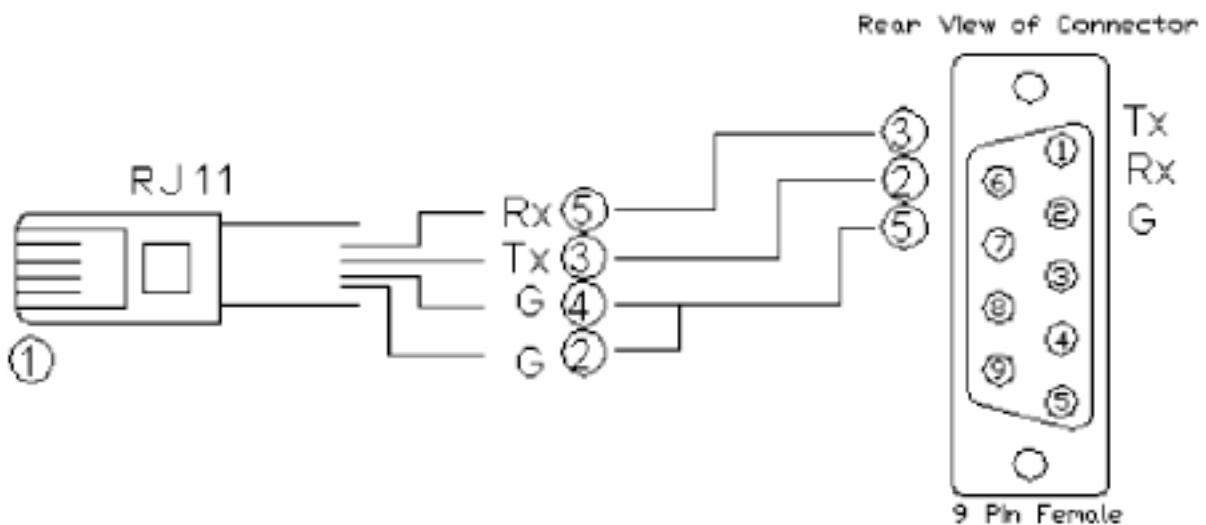

GENERAL INFORMATION

SIMPLWINDOWS NAME	WallWizard SA52/TA55 Serial v1.0
CATEGORY	Motorized Mount
VERSION	1.0
SUMMARY	This module provides control for the WallWizard SA52/TA55 motorized mount.
GENERAL NOTES	N/A
CRESTRON HARDWARE REQUIRED	C2COM-2/3, C2COMI, ST-COM
SETUP OF CRESTRON HARDWARE	RS232 Baud: 2400 Parity: None Data Bits: 8 Stop Bits: 1
CABLE DIAGRAM	N/A



Partner: WallWizard
Model: SA52/TA55
Device Type: Motorized Mount



CONTROL

Stop	D	[SA52/TA55] Pulse to stop motion.
Up	D	[TA55] Pulse to move up.
Down	D	[TA55] Pulse to move down.
Left	D	[SA52] Pulse to move left.
Right	D	[SA52] Pulse to move right.
Home	D	[SA52/TA55] Pulse to move to home position.
Memory_1_Recall	D	[SA52/TA55] Pulse to recall memory 1 position.
Memory_2_Recall	D	[SA52/TA55] Pulse to recall memory 2 position.
Memory_1_Store	D	[SA52/TA55] Pulse to store current position to memory 1.
Memory_2_Store	D	[SA52/TA55] Pulse to store current position to memory 2.
To_Device	D	Serial signal to be routed from a 2-way serial com port.

FEEDBACK

From_Device	S	Serial signal to be routed to a 2-way serial com port.
--------------------	---	--

Partner: WallWizard
Model: SA52/TA55
Device Type: Motorized Mount

**TESTING**

OPS USED FOR TESTING	v4.003.0015
SIMPL WINDOWS USED FOR TESTING	v3.01.37
CRESTRON DATABASE USED FOR TESTING	v26.00.008.00
DEVICE DATABASE USED FOR TESTING	V34.00.012.00
SAMPLE PROGRAM	WallWizard SA52-TA55 Serial v1.0 Demo PRO2.smw
REVISION HISTORY	V1.0 – Initial release.