

Partner: Bose
Model: ESP-88
Device Type: Input Interface v1.0

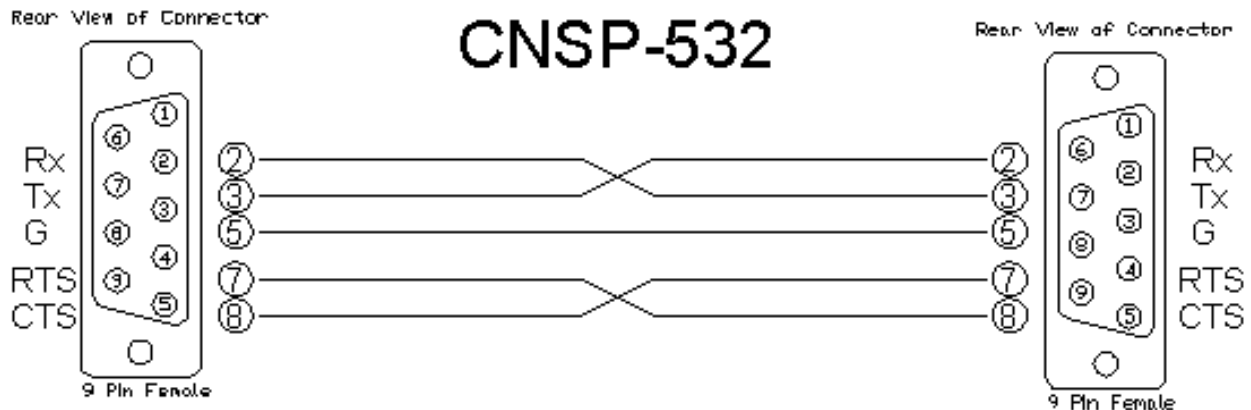

GENERAL INFORMATION

SIMPLWINDOWS NAME:	Bose ESP Input Interface v1.0
CATEGORY:	Multi-Zone
VERSION:	1.0
SUMMARY:	This module controls a Input object within the Bose ESP-88 configuration.
GENERAL NOTES:	This module controls a Input object within the Bose ESP-88 system. Please note that in the Bose configuration the Input name needs to be prefaced with an “#” (such as #Input1). This enables the Bose unit to send unsolicited real-time feedback to the Crestron unit when any changes are made.
CRESTRON HARDWARE REQUIRED:	X-Series Processor, CNX-COM2, ST-COM, 2-Series Processor, C2COM3
SETUP OF CRESTRON HARDWARE:	RS232 Baud: 38400 Parity: N Data Bits: 8 Stop Bits: 1
VENDOR FIRMWARE:	None
VENDOR SETUP:	None
CABLE DIAGRAM:	CNSP-532



Partner: Bose
Model: ESP-88
Device Type: Input Interface v1.0

CONTROL:

Input_Level_In	A	Use to set input level. Signed. Range from -32768 to +32767. Connect to slider definition.
Input_Level_Up/Down	D	Press to increase or decrease input level.
Input_Mute_On/Off/Toggle	D	Pulse to turn input mute on or off.
Input_Enable	D	Latch high to enable serial communications with unit.
Input_Read	D	Pulse to poll for current input status.
From_Device	S	Serial signal to be routed from an RS-232C port

FEEDBACK:

Input_Level_Out	A	Indicates the current input level. Range from -32768 to +32767. Connect to slider definition.
Input_Level_Out_Text	S	Text field indicating input level. Range is from -60.0 to 12.0db.
Input_Mute_Is_On/Off	D	Indicates the current input mute status.
To_Device	S	Serial signal to be routed to an RS-232C port

PARAMETER:

Step	A	Use to set the volume up/down step increment.
Module Name	D	The name of the Input module in the Bose ESP-88 configuration that this module will be communicating with. Note: The module name in the Bose configuration needs an “#” prefix, while the name entered in this module does not.

Partner: Bose
Model: ESP-88
Device Type: Input Interface v1.0

**TESTING:**

OPS USED FOR TESTING:	v3.155.1240
SIMPL WINDOWS USED FOR TESTING:	v2.10.32
DEVICE DB USED FOR TESTING:	20.03.013.00
CRES DB USED FOR TESTING:	20.01.008.00
SYMBOL LIBRARY USED FOR TESTING:	576
SAMPLE PROGRAM:	Bose ESP-88 Demo PRO2
REVISION HISTORY:	v1.0 – Initial Release